

Assembly Instructions

Elevate Student Desk

04068471: -EJA

04068604: -ADJ



Before you begin, please make sure all parts and proper quantities are included. (See Part Identifier Key) Any parts damaged during shipment must be reported within 24 hours of receipt. To report information regarding damages or if you have any questions, please call 800.242.2303.

Tools Required

- Screw gun
- 4mm hex bit
- Phillips head screwdriver
- Drill bit extension

NOTE: These Assembly Instructions are based on the assembly of the Elevate Adapt XL (U.S. Patent D780487) Student Desk with an adjustable height base. Type and quantity of parts may vary depending on which desk or table is ordered. These instructions comply with all Elevate Student Desks.

Step 1:

- Take base out of box and place on a protected flat surface.
- Insert center post into the base.

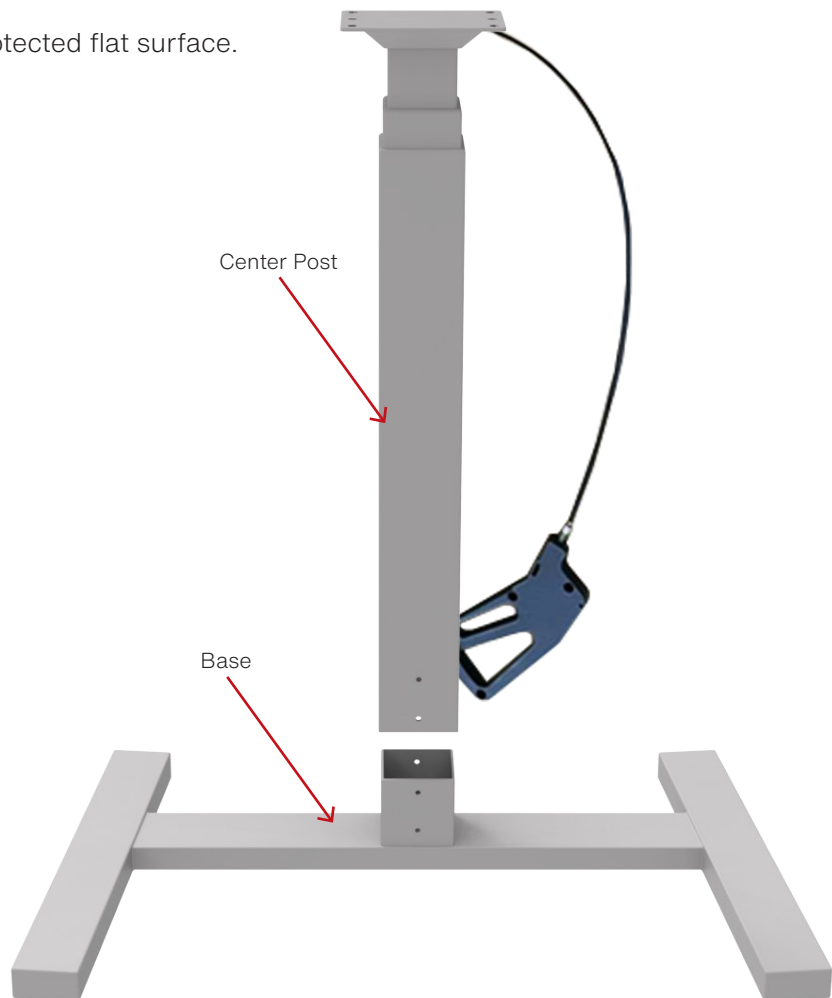

Assembly Instructions

Elevate Student Desk

04068471: -EJA

04068604: -ADJ

Step 2:

- Place and center attachment plate **with countersinks facing up** on the top of the center post.
- Place (6) hex head machine screws through the innermost holes in the attachment plate.
- Secure attachment plate to the center post by tightening the hex head machine screws using the 5mm Allen wrench.

Qty 6



5/16" x 12mm hex head machine screw

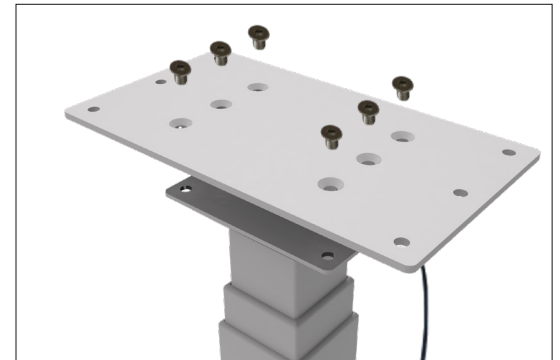
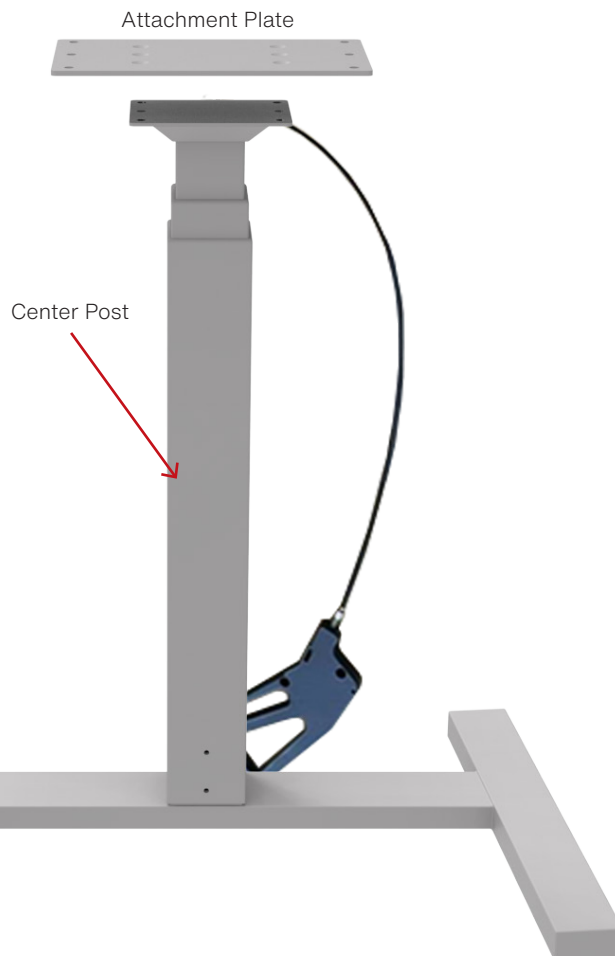

Assembly Instructions

Elevate Student Desk

04068471: -EJA

04068604: -ADJ

Step 3:

- Place top on a protected flat surface so that threaded inserts are facing up.
- Remove center post from the base and set the base to the side.
- Place the attachment plate on the bottom of the top, aligning the holes in the attachment plate to the inserts in the bottom of the top. **See image below for the correct placement.**
- Place joint connector bolts w/loctite through the outermost holes in the attachment plate.
- Secure attachment plate to the top by tightening the joint connector bolts using a 4mm Allen wrench or 4mm hex bit and screw gun.

Qty 6



1/4"-20x19mm joint connector bolt w/ loctite

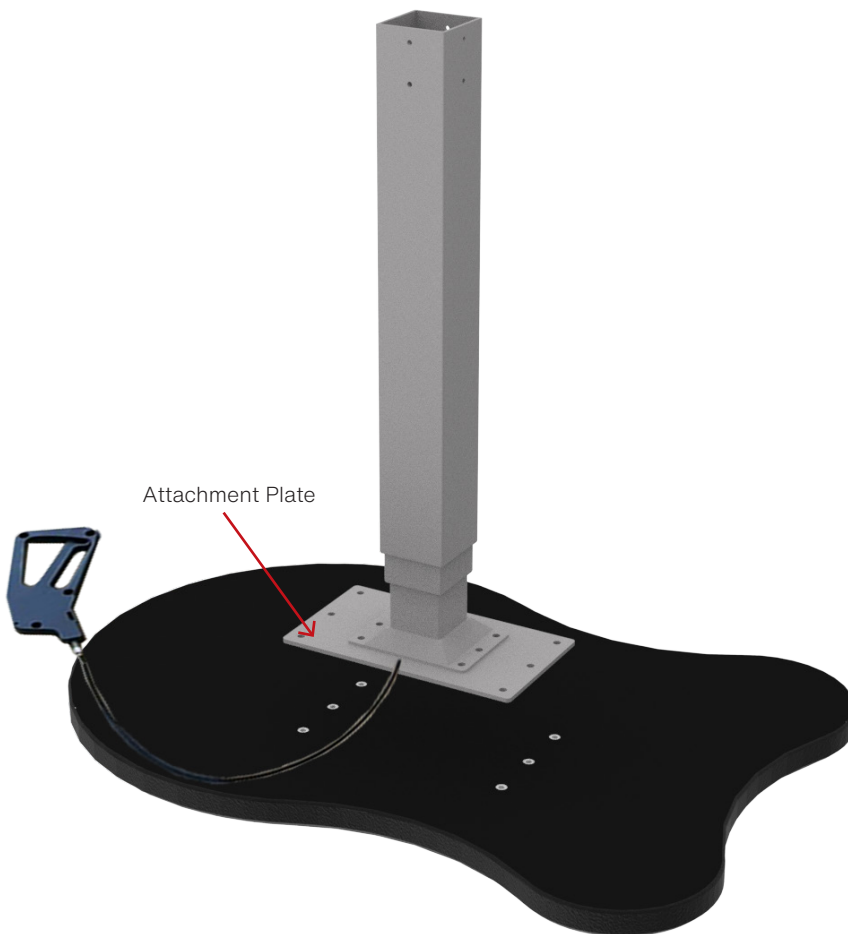
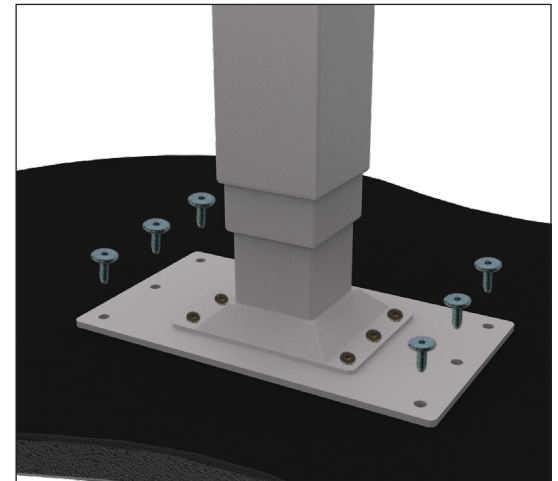

***Correct placement of attachment plate/ pedestal:** Cord for plastic handle should be turned to the BACK side (side with shorter distance to edge) of the top.

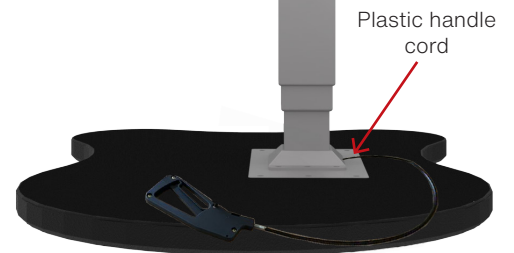

Assembly Instructions

Elevate Student Desk

04068471: -EJA

04068604: -ADJ

Step 4:

- With the top still on the ground, take the base you previously set to the side and insert the square tube onto the center post. See image below for the correct placement.
- Slide (1) washer onto each flat head bolt w/loctite. Place each of them through the holes in the base.
- Secure base to the center tube by tightening the flat head bolts w/ loctite using a 4mm Allen wrench or 4mm hex bit and screw gun.

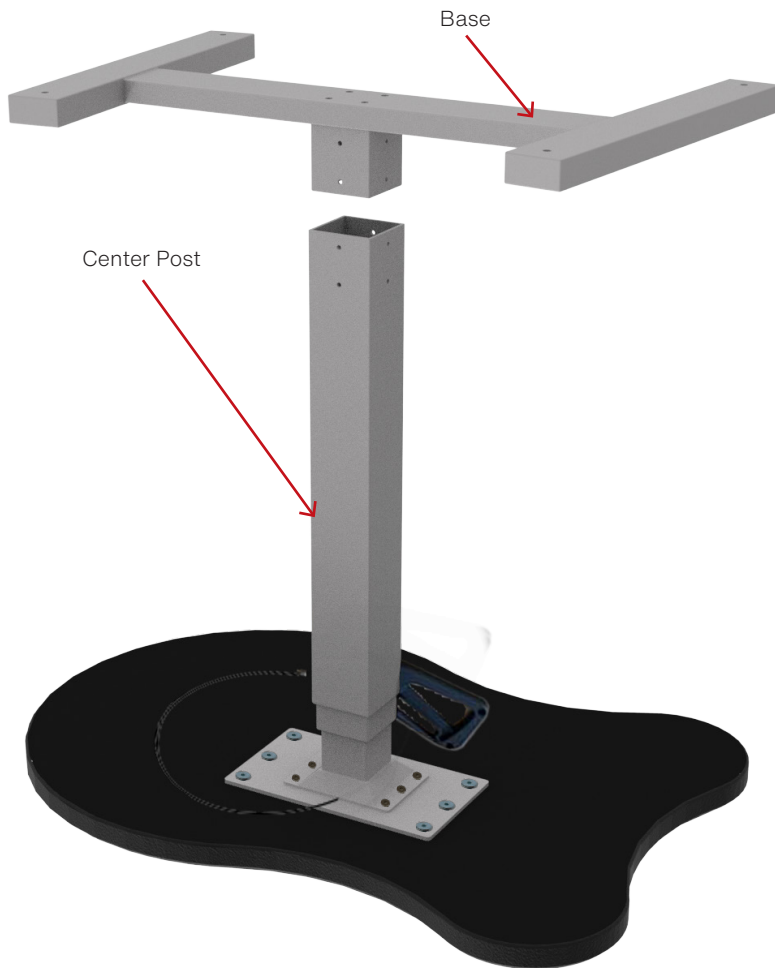

Qty 4



1/4" x 110mm flat head bolt w/loctite (-ADJ)

1/4" x 82mm flat head bolt w/loctite (-EJA)

Qty 4



16mm x 16ga washer

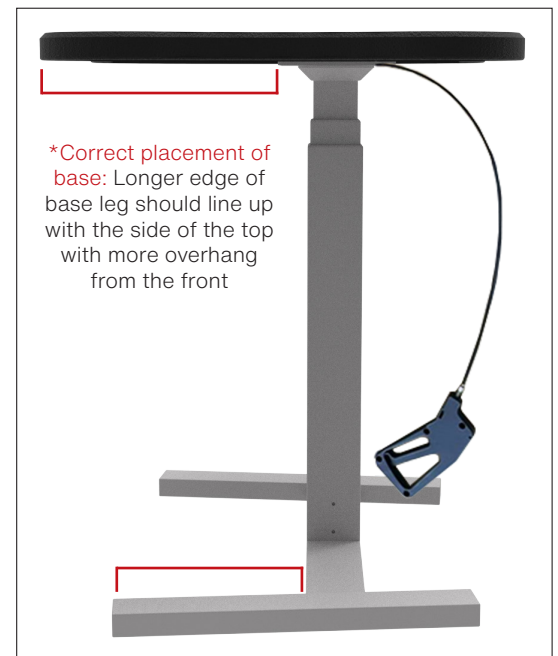
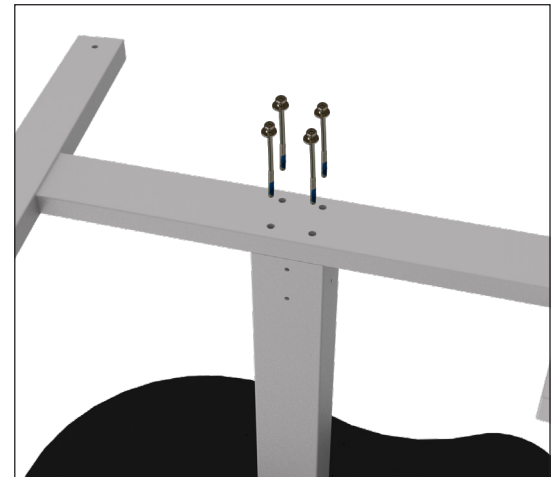

Assembly Instructions

Elevate Student Desk

04068471: -EJA

04068604: -ADJ

Step 5:

- Place (2) joint connector bolts **through the front side of the center post**, tighten bolts using a 4mm Allen wrench or 4mm hex bit and screw gun.
- After tightening the joint connector bolts in the front side, continue to the back side, and then to the right and left sides of the center post.
- **Please take note that images are for illustrative purposes only and the frame may be different from the image shown in these instructions.**

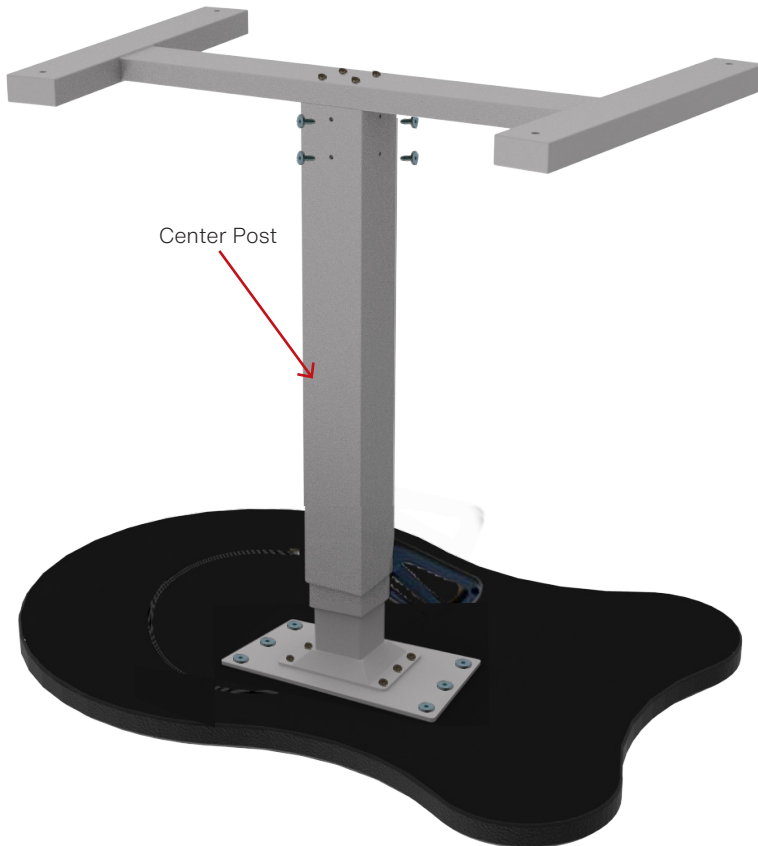

Qty 4 (-EJA)
Qty 8 (-ADJ)



1/4"-20x19mm joint connector bolt w/ loctite



Assembly Instructions

Elevate Student Desk

04068471: -EJA

04068604: -ADJ

Step 6:

- Place stem of optional footing into the hole on the leg. Rotate clockwise until fully inserted into leg.
- Casters are NOT to be used as a leveling device.
- Tighten with a 14mm open-ended wrench (only with the dual wheel casters.)
- Repeat for each caster or glide.

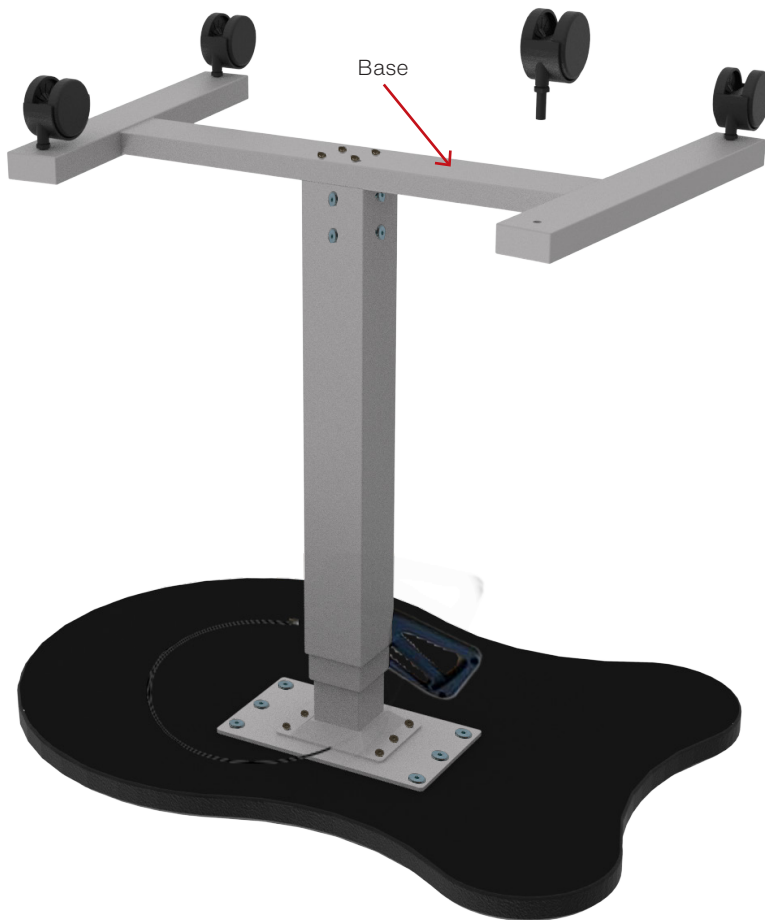

Qty 4



Dual wheel soft tread locking caster

Qty 4



2.5" Grand Hank glides

Qty 1



14mm open-ended wrench

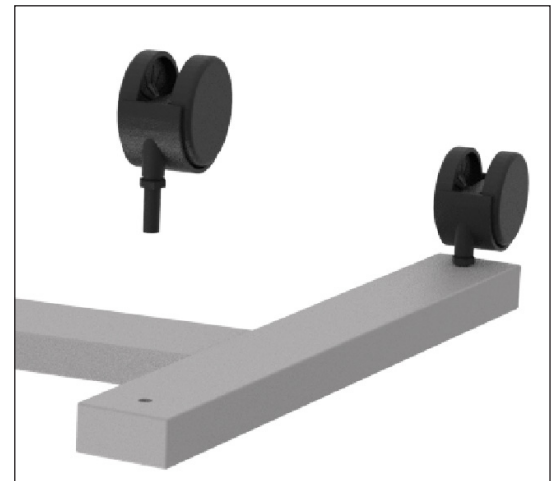

Assembly Instructions

Elevate Student Desk

04068471: -EJA

04068604: -ADJ

Step 7:

- Place the plastic handle on the bottom of the top and align the pre-drilled holes in the handle with the pre-drilled pilot holes in the top.
- Secure the handle to the top with (4) Phillips head screws, using a Phillips head screwdriver.

Qty 4



4mm x 15mm Phillips head screw

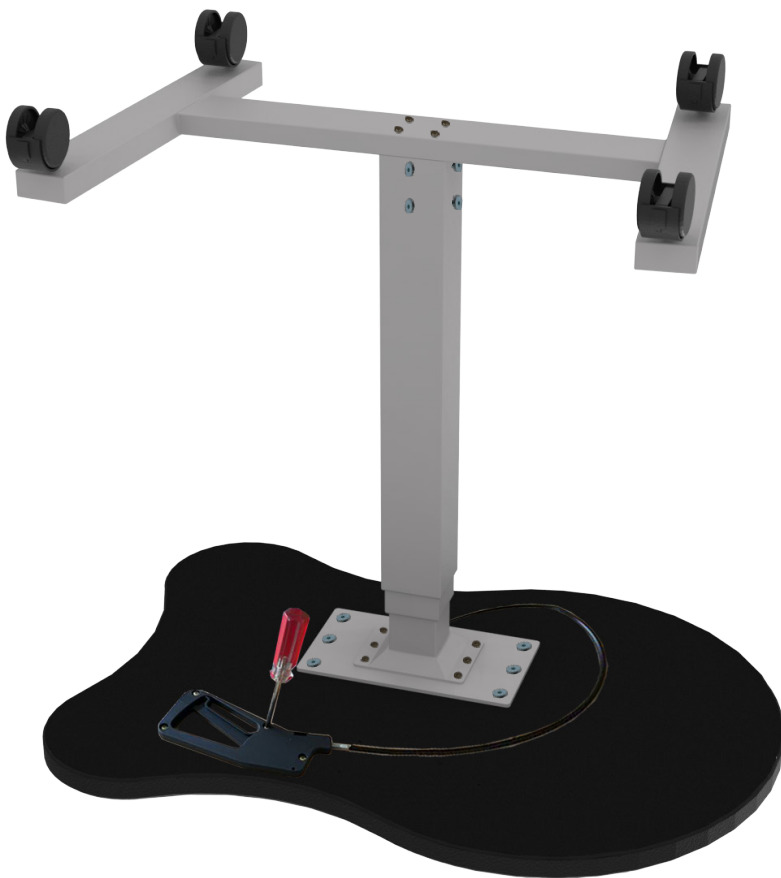
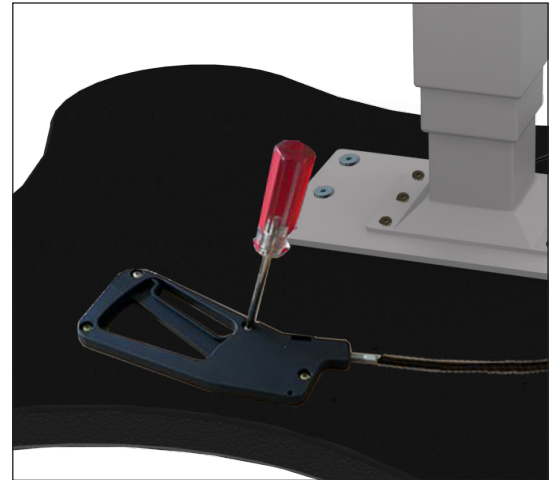

Assembly Instructions

Elevate Student Desk

04068471: -EJA
04068604: -ADJ

Step 8:

- Slide the cord through the (2) plastic wire holders.
- NOTE: There will not be any pre-drilled pilot holes for the plastic wire holders. Place the wire holders near the locations shown in the images on this page.
- Attach plastic wire holders using (2) Phillips head screws.
- The cord should be fluid without any kinks.

Qty 2



4mm x 15mm Phillips head screw

Qty 4





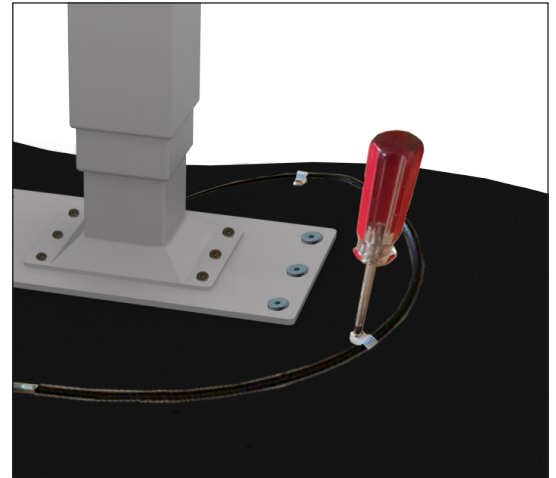
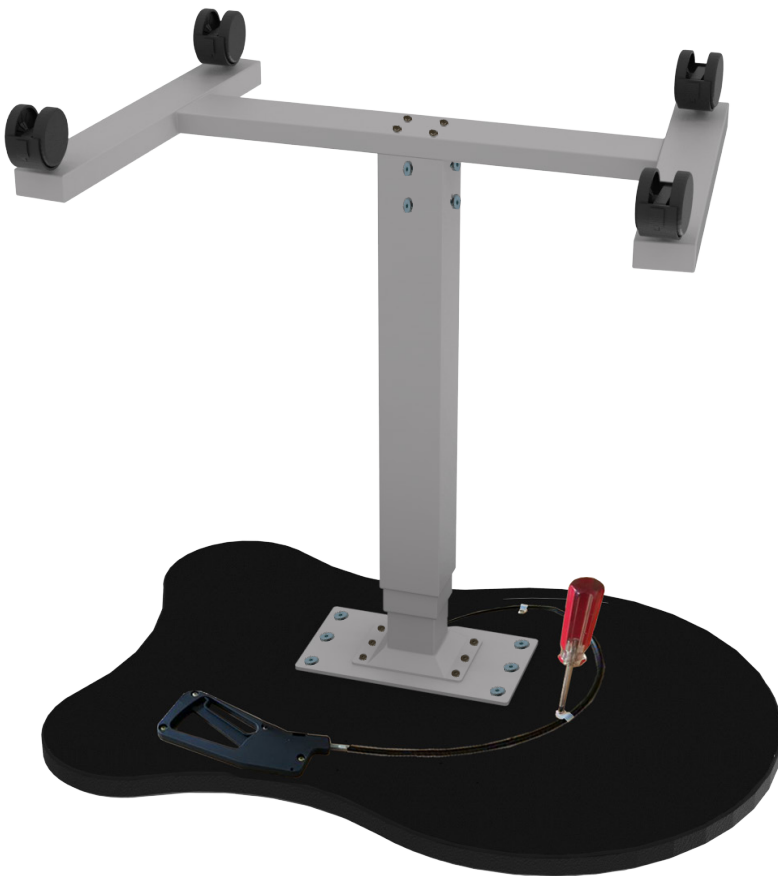







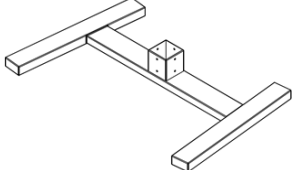



Plastic wire holder



Step 10:

- With the help of another person, flip desk over to the upright position.

Part Identifier Key

Step # Part is Used In	Part #	Description	Qty.	
	04068471-01 04068604-01	Base (-EJA) Base (-ADJ)	1	
	04068471 04068604	Outer pedestal (-EJA) Outer pedestal (-ADJ)	1	
		4mm Allen wrench (Used to tighten joint connector bolts throughout assembly.)	1	
Step 2	04068471-05 04068604-05	Attachment plate 10.630" x 5.906" x 7Ga. (-EJA) OR Attachment plate 10.630" x 5.906" x 7Ga. (-ADJ)	1 1	
Step 2		Hex head machine screw 5/16"x12mm	6	
Step 2		5mm Allen wrench	1	
Step 3	04088861	Joint connector bolt w/Loctite 1/4"-20x19mm	6	
Step 4		Flat head bolt w/Loctite 1/4"-20x82mm (-EJA) or Flat head bolt w/Loctite 1/4"-20x110mm (-ADJ)	4 4	
Step 4		Washer dia. 16mmx14Ga.	4	
Step 5	04088861 04088861	Joint connector bolt, 1/4"-20x19mm w/Loctite (-EJA) OR Joint connector bolt, 1/4"-20x19mm w/Loctite (-ADJ)	4 8	
Step 6	040164	2.5" Grand Hank nylon glide, 3/8"-16 x 1" (Pre installed to the base by supplier)	4	
Step 6	04067540	Dual Wheel Soft Tread locking casters	4	
Step 6		14mm open-ended wrench	1	
Step 7		Phillip screw, 4mmx15mm	4	
Step 8		Plastic wire holder	2	
Step 8		Phillip screw, 4mmx15mm	2	