



Assembly Instructions

High Density Storage

Before you begin, please make sure all parts and proper quantities are included. (See Part Identifier Key) Any parts damaged during shipment must be reported within 24 hours of receipt. To report information regarding damages or if you have any questions, please call 800.242.2303.

IMPORTANT PRECAUTIONS:

- Installation site must be level. If the floor level varies by more than 1/8" over a 3 foot span, installation in another location should be considered. Floor should be free of dirt and debris before installation begins.
- The system should be installed by a skilled carpenter who is familiar with the installation instructions.
- Installation is required next to a side wall. This ensures unit is installed square to the wall, sidewalls and floor, according to these assembly instructions.
- Unit's plate and mobile frame must be secured to the floor using appropriate fasteners for that surface material. This unit without proper installation could be hazardous to the users or property.
- If installing over carpeting, it should be commercial grade carpet without a foam backing pad.

NOTE: Instructions for installing all cabinets except the last cabinet in a row.

Step 1:

- Start with the first cabinet to be installed next to a wall. Attach mounting plate assembly to floor using appropriate fasteners (not included).
- Be sure that the plate is parallel to the wall next to it and the threaded studs are away from the wall behind cabinets.

Step 1

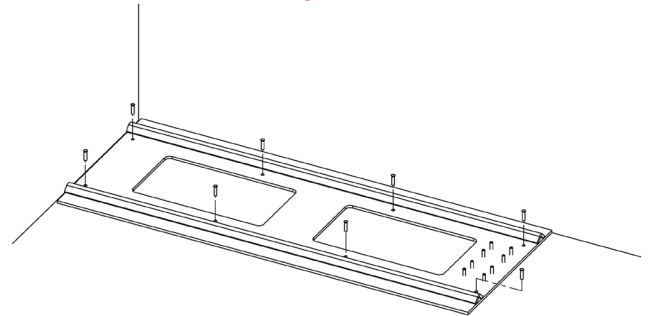

Step 2:

- Set the mobile frame on to the mounting plate so that the V-groove wheels ride on the angle and the rubber wheels ride on the floor.

Step 2

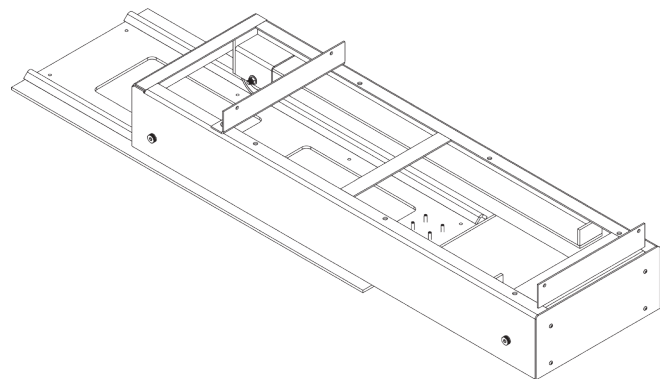

Tools Required

- Phillips screwdriver
- Screw gun
- 4mm Allen wrench OR
- 4mm Hex bit
- Hammer
- Carpenter's square
- Level

Step 3:

- Place the anti-tip/stop bracket on 1/4"-20 studs and fasten with (4) 1/4" flat washers and (4) 1/4-20 reverse lock nuts.
- Repeat **Step 3** for the other bracket.

Step 3

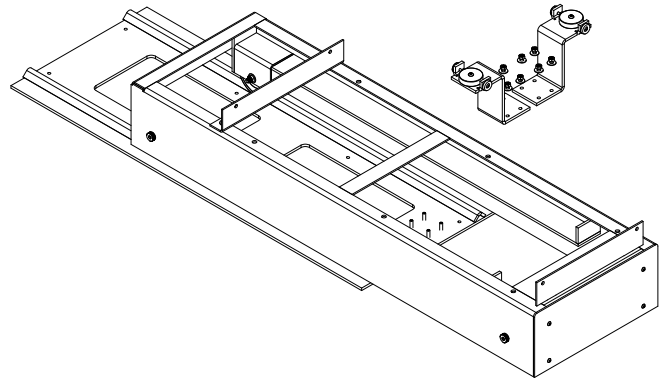

Step 4:

- Place the cabinet onto mobile frame so that access to the cabinet is from the preferred direction.

Step 5:

- Fasten cabinet to mobile frame using (6) 1/4"-20x40 LP bolt w/loc tite through the bottom of the cabinet.

Step 6:

- Bolt cabinet to the bracket using (2) 1/4"-20 x 1 3/8" joint connector bolts w/loc tite and (2) 1/4"-20 nylon insert lock nuts.

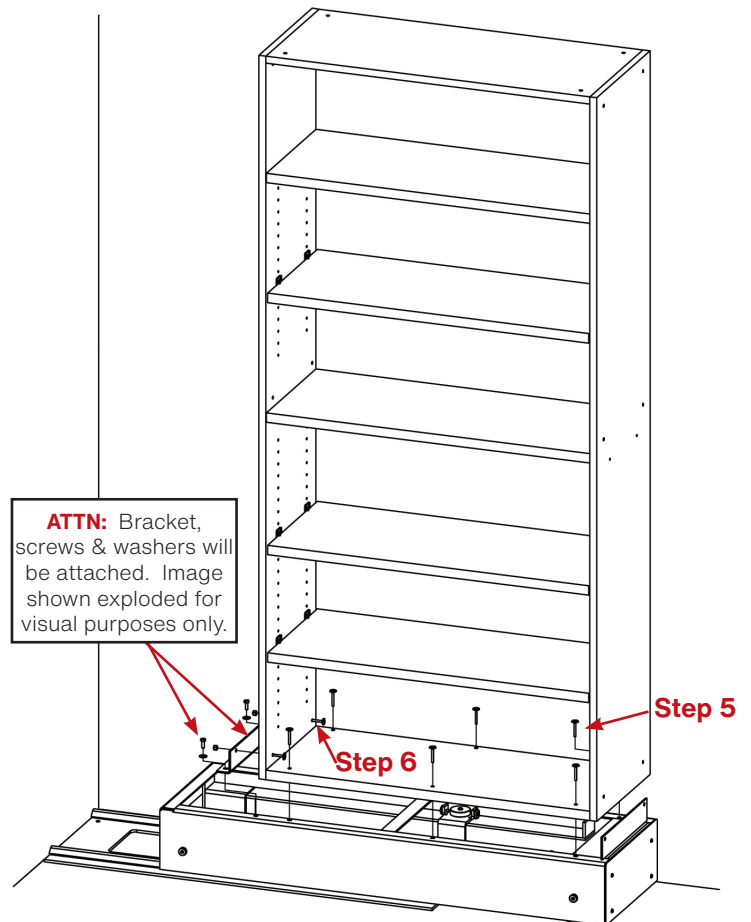

Assembly Instructions

High Density Storage

Step 7:

- Install the front panel using (6) 1/4"-20 x 1 3/8" joint connector bolts w/ loc tite.

Step 8:

- Once the front panel is attached, install the stainless steel bar pull using (2) #8-32x2-1/4" Phillips panhead screws.

Step 9:

- Install the label holder in pre-drilled location with screws provided with the label holder.

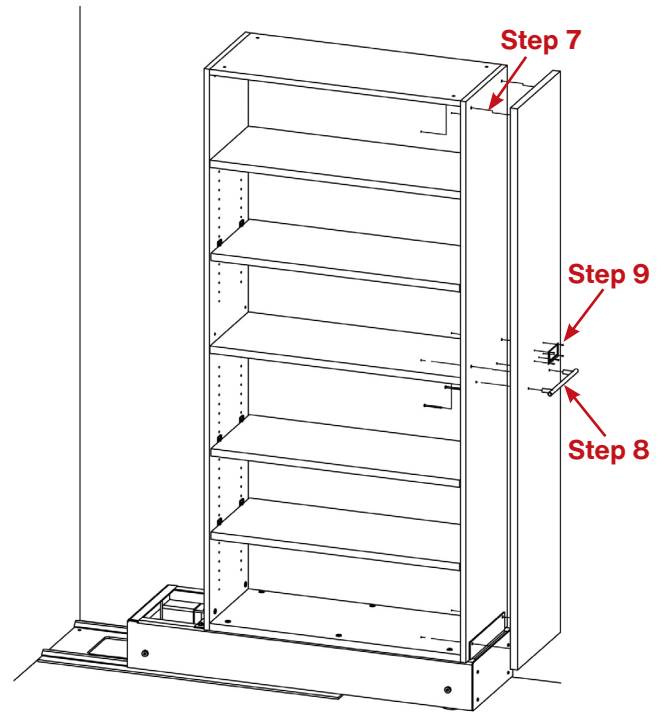

Step 10:

- Install top onto cabinet so that the large overhang is to the back of the cabinet and attach using (4) 1/4"-20 x 1 3/8" joint connector bolts w/ loc tite.
- Repeat **Steps 1 - 10** until all units are assembled, except the final cabinet.

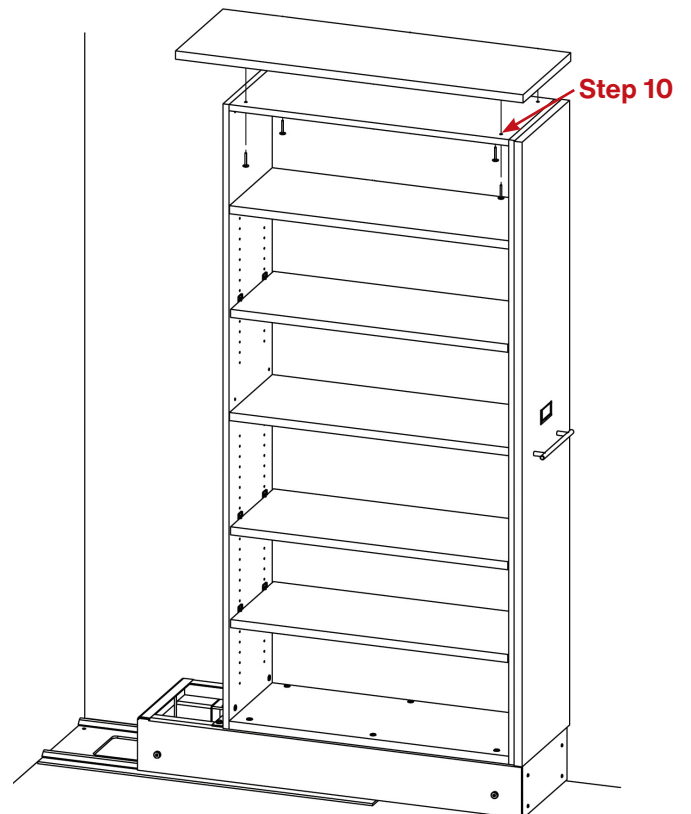

Assembly Instructions

High Density Storage

Last Cabinet

Step 1:

- Attach mounting plate assembly to floor using appropriate fasteners (not included).

DO NOT install mobile base onto track until the cabinet has been attached to the mobile frame.

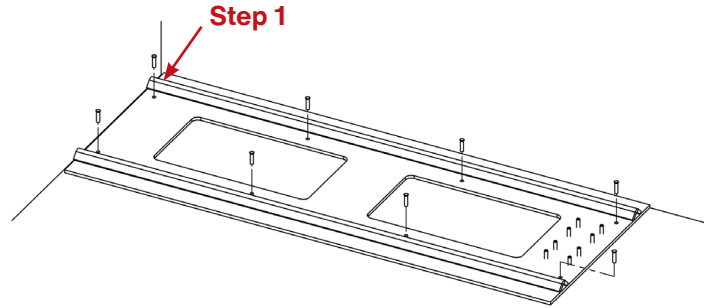

Step 2:

- Remove the front plate from the mobile base. Set aside as it will be reattached when installation is completed.

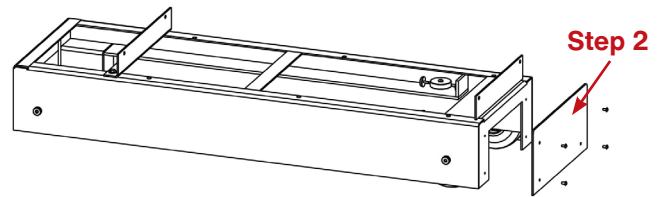

Step 3:

- Place the cabinet onto mobile frame so that access to the cabinet is from the preferred direction.

Step 4:

- Fasten cabinet to mobile frame using (6) 1/4"-20x40 LP bolt w/ loc tite through the bottom of the cabinet.

Step 5:

- Bolt cabinet to the bracket using (2) 1/4"-20 x 1 3/8" joint connector bolts w/ loc tite and (2) 1/4"-20 nylon insert lock nuts.

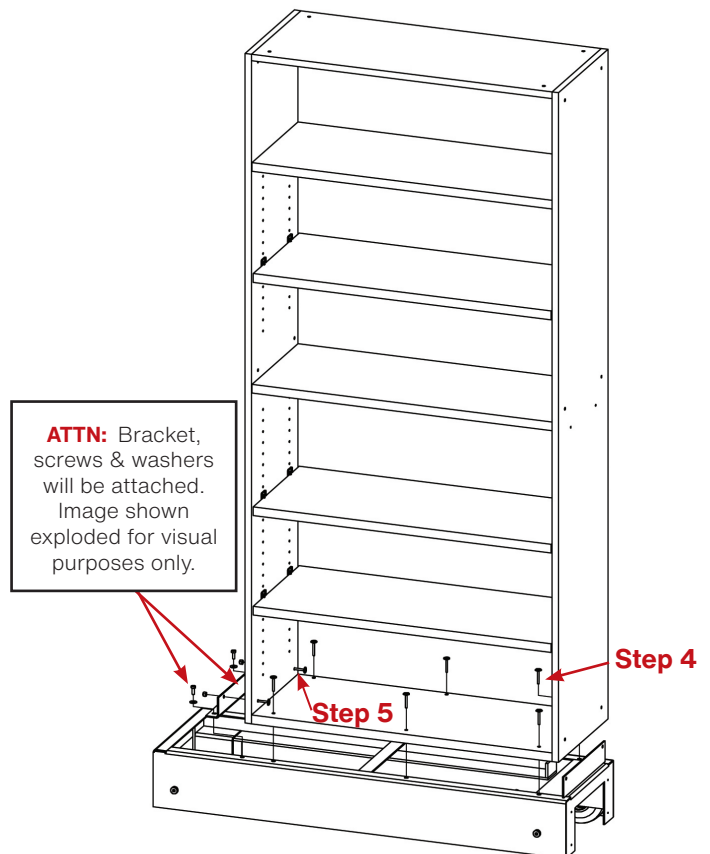

ATTN: Bracket, screws & washers will be attached. Image shown exploded for visual purposes only.

Assembly Instructions

High Density Storage

Last Cabinet

Step 6:

- Install the front panel using (6) 1/4"-20 x 1 3/8" joint connector bolts w/ loc tite.

Step 7:

- Once the front panel is attached, install the stainless steel bar pull using (2) #8-32x2-1/4" Phillips panhead screws.

Step 8:

- Install the label holder in pre-drilled location with screws provided with the label holder.

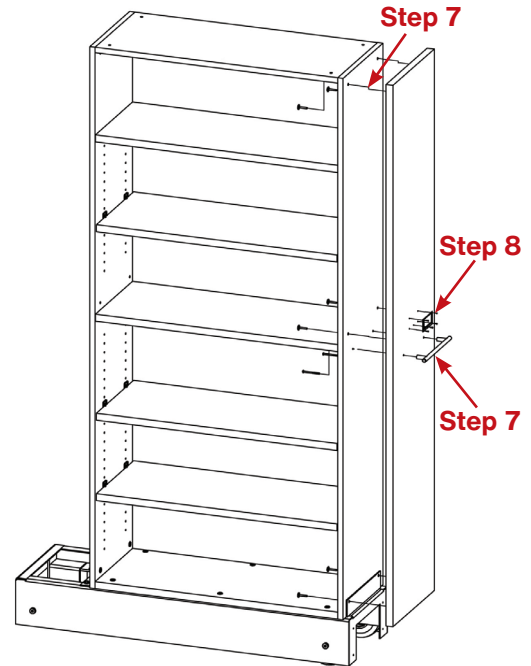

Step 9:

- Install top onto cabinet so that the large overhang is to the back of the cabinet and attach using (4) 1/4"-20 x 1 3/8" joint connector bolts w/loc tite.

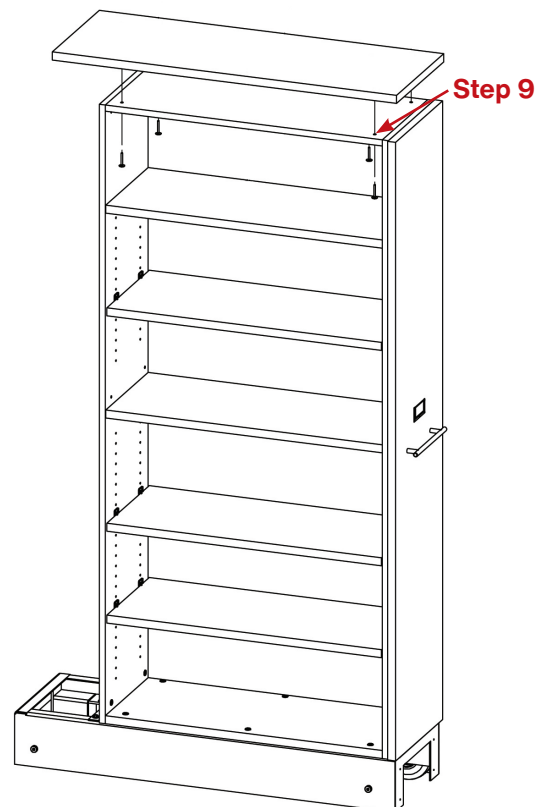

Assembly Instructions

High Density Storage

Last Cabinet

Step 10:

- Once the frame and the cabinet are assembled, set the mobile frame onto the mounting plate so that the V-groove wheels ride on the angles and the rubber wheels ride on the floor.

Step 11:

- Use the cutout on the front of the frame to place the anti-tip/stop bracket on $\frac{1}{4}$ "-20 studs and fasten with (4) $\frac{1}{4}$ " flat washers and (4) $\frac{1}{4}$ "-20 reverse lock nuts.
- Repeat **Step 11** for the other bracket.

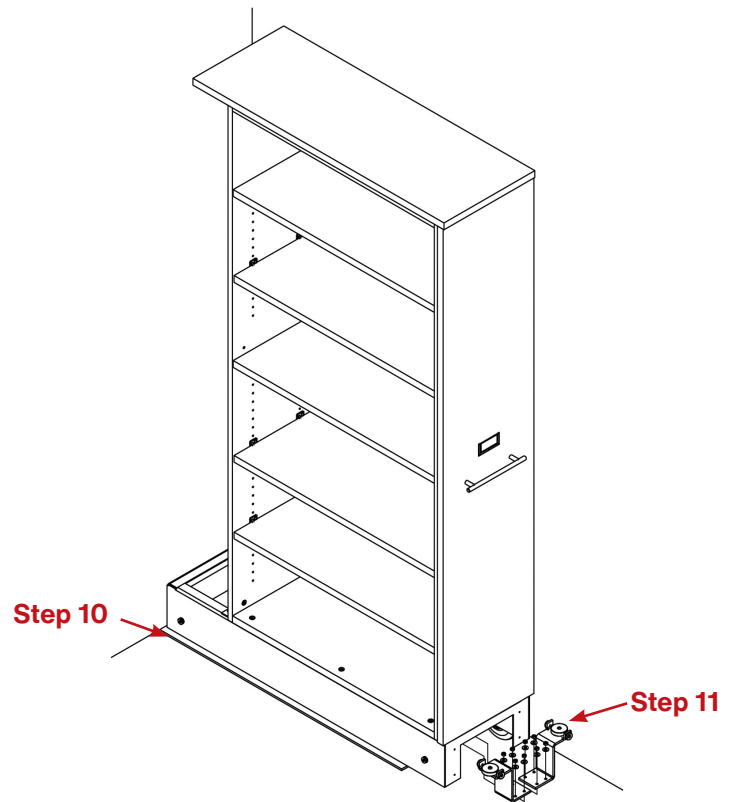



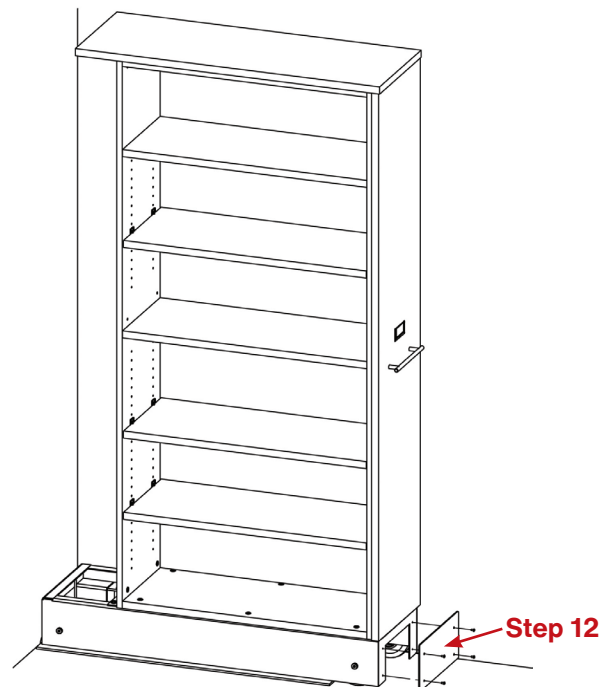

Step 12:

- Reinstall the removable front panel.



Part Identifier Key

	Part #	Small Parts List Per Cabinet	Qty Per Cab.	
HDSKit	04009610	5.841x6.375x3.376 anti-tip / stop brackets	2	
	0404232	1/4" flat washers	8	
	04009421	1/4"-20 reverse lock nuts <i>(Used to attach anti-tip / stop brackets to mobile frame)</i>	8	
	0406526	1/4"-20x40 LP bolts w/loc tite <i>(Used to attach bottom shelf(base) to the mobile frame)</i>	6	
	0406686	1/4"-20 x 1 3/8" joint connector bolts w/loc tite	2	
	04009015	1/4"-20 nylon insert lock nuts black <i>(Used to attach cabinet to bracket)</i>	2	
	0406686	1/4"-20 x 1 3/8" joint connector bolts w/loc tite <i>(Used to attach front panel)</i>	6	
	04009279	192mm stainless bar pull <i>(Do not use the screws that are packaged with the bar pull)</i>	1	
	04009296	#8-32x2 1/4" Phillips panhead screws <i>(Used to attach the stainless bar pull)</i>	2	 
	0400988	Kit with label holder for 1 1/2"x2 15/16" card & screws	1	
	0406686	1/4"-20 x 1 3/8" joint connector bolts w/loc tite <i>(Used to attach top to cabinet)</i>	4	