

NUCLEUS WORKSTATION

NOTE: Before you begin, please make sure all parts and proper quantities are included. Any parts damaged during shipment must be reported within 24 hours of receipt. To report information regarding damages or if you have any questions, please call 800.242.2303.

NOTE: These instructions are based on model #CLN9110-3-T3040-AC. These instructions work for all Nucleus Workstation models. Product images are for illustrative purposes only and may differ from actual product.

TOOLS NEEDED



PARTS

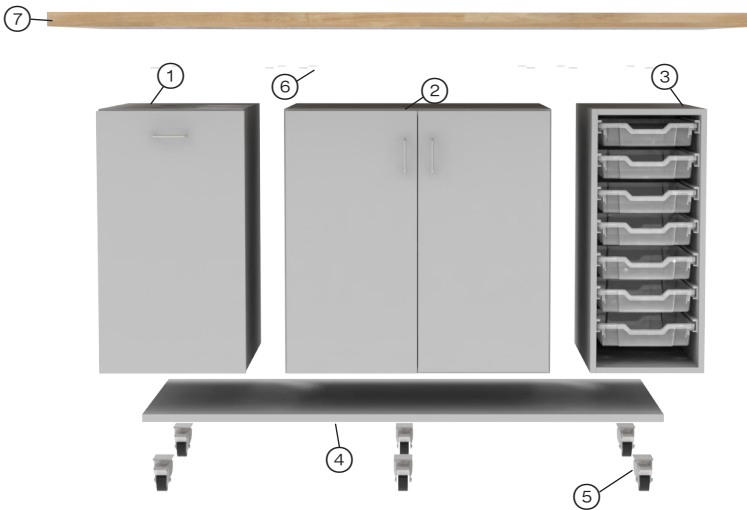

PARTS x QTY

#	DESCRIPTION x QTY
1	Pullout Trash Cabinet x 1
2	Double Door Base Cabinet x 1
3	Tote Cabinet x 1
4	Caster Base x 1
5	Casters x 6
6	Nylon Washers x 12
7	Hardwood Top x 2

HARDWARE x QTY

 1/4" - 20x30mm joint connector bolt x 8 0400236	 1/4"-20x25mm joint connector bolt x 24 04066947
 1/4" - 20x17mm joint connector nut x 8 0404229	 1/4"-20x35mm joint connector bolt x 12 0406686-WO
 #10 1 1/2" square-drive flat head screw for wood x 12 040681	 Nylon Washer x 12 040371
 3" heavy duty plate casters w/o brake x 4 0400484	
 3" heavy duty plate casters w/ brake x 2 0400485	



The assembly of this workstation requires the assistance of another person.



NOTE: Hardware packs are included in packaging. You may receive more hardware than needed. Discard any extra hardware after assembly.

ASSEMBLY

1. Remove the two waste bins from the cabinet.

Place cabinets ① ② & ③ on a protected flat surface with their sub-bottoms facing up. (Upon installer's discretion, remove doors (excluding trash door), shelving & totes before turning any of the cabinets over to lessen the weight of the cabinets.)

Align the pre-drilled holes on the sides of all three cabinets with each other.



NOTE: Please use the below image for the correct placement of each cabinet.



2. With cabinets aligned together, place the 1/4"-20 x 30mm joint connector bolt w/ loctite through pre-drilled hole on the inside of one of the cabinets making sure bolt is pushed as far as it can go.

While holding the joint connector bolt flush to the cabinet, take a 1/4"-20x17mm joint connector nut and attach it to the end of the bolt (located in other base cabinet) turning it clockwise until it's completely on. Use a 4mm Allen wrench or 4mm hex bit and a screw gun to tighten as needed.

Repeat Step 2 with the remaining bolts and connector nuts so all three cabinets are attached together.



NOTE: If you did not remove the totes or waste bins in Step 1, you will need to remove them in order to gain access to the pre-drilled holes located inside of all three cabinets.



3. With all three cabinets attached together, take caster base and center it on the cabinets with threaded inserts facing up.

Using #2 square bit, attach caster base to the cabinets using #10 1 1/2" square-drive flat head screws.

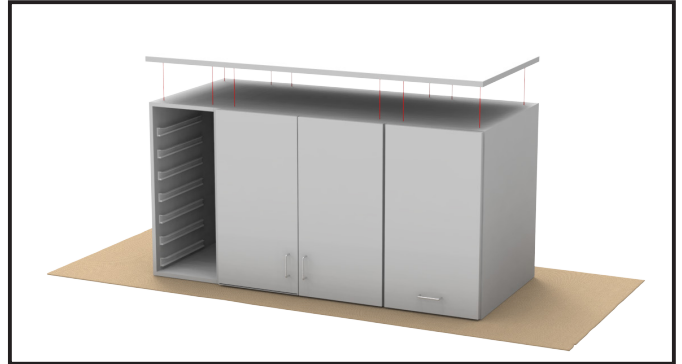

4. Align caster with the threaded inserts.

Use the 1/4"-20x25mm joint connector bolts to attach casters to the cabinet.

Repeat for the remaining casters. (See image below to see the location for the two locking casters.)

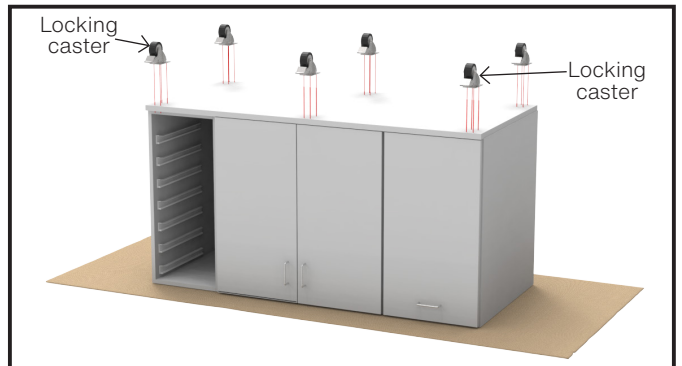

5. With someone's help, position the cabinet right side up. Make sure to have all the locking casters' levers pushed down to secure cabinet in place.

ASSEMBLY

6. If laminate or phenolic top was ordered, proceed to step 9. If assembling a hardwood top that has a depth greater than 36", top will be in 2 pieces and will be 0.5" undersized on length. Tops for units with the trash drawer will be 2 different sizes. (See image in step 7 for correct placement.) Place both top halves face down on a protected flat surface. Align together the dog bone holes on both tops.

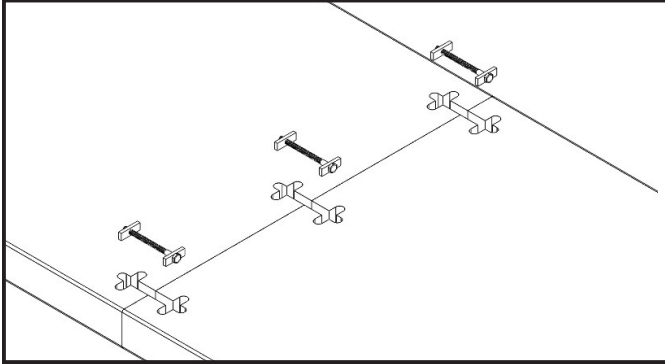

7. Adjust Tite joint fastener to the size of the field joint opening and then place the fastener into each opening. Using a 7/16" wrench, tighten each fastener so that both tops are securely clamped together.

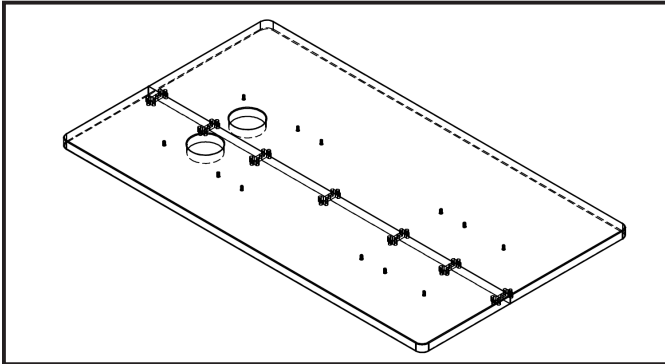

8. Place nylon washers atop cabinet sub-tops, aligning with pre-drilled holes in the sub-top as shown in the image below. (Washers are depicted in red for illustrative purposes only.)

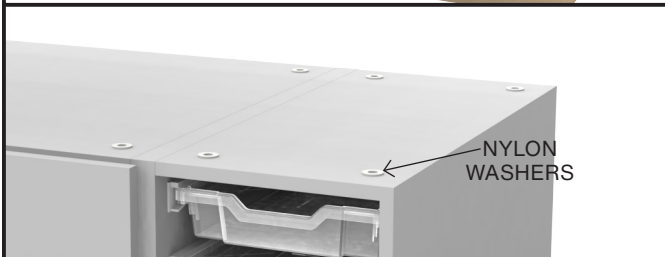

9. Place top on cabinets. Align pre-drilled holes on the cabinets with threaded inserts in the top.

Using a 1/4-20x35mm joint connector bolt (going through one of the cabinets) insert the bolt through the pre-drilled hole up into the threaded insert of the top. Use a 4mm Allen wrench or 4mm hex bit and a screw gun to fasten the bolt into place.

After the first bolt is fastened, proceed attaching the remaining bolts in that cabinet. (4 bolts per cabinet)

Repeat Step 9 for the other two cabinets.

If shelving, doors, totes and trash bins were removed, place them back into place.



10. Wire pulls are factory installed on the inside of doors to prevent damage in transit. (Use the clear tab to open the double doors.)

Unscrew each wire pull handle using a Phillips drill bit and a screw gun.

Reattach with wire pull on the outside of the cabinet.

Repeat for each of the wire pulls for both cabinets.

Remove clear tab on door.

